

ICL701-4 VRD/POL Inductor

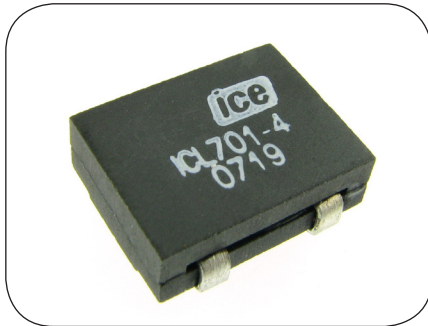

Features

- Designed for use with IDT's proprietary coupled inductor multi-phase DC-DC converter topology
- Low height and small size allows use in both imbedded (VRD) and module (VRM) applications
- Robust SMD package is compatible with SMT assembly process handling

Applications

- VRDs (Imbedded)
- VRMs (Module)
- POLs
- VRM 10.x / VRM11 based designs.
- DDR2/3 memory

The ICL701-4 using IDT's coupled inductor technology solves the most pressing problem facing IA-32 VRDs and VRMs. This patented technology solves the trade-off between efficiency and elimination of bulk capacitors by dramatically lowering the VRM output inductance while using industry-standard components and relatively low switching frequencies. This technology provides superior transient response performance to higher frequency solutions due to the unique method of coupling between phases, and enables high-current designs with little or no electrolytic output bypass capacitance. The ICL701-4 coupled inductor can be used in both VRD and module VRM applications. Its small size and low height make it possible to design high-density VRMs and to fit the inductors very close to the CPU socket in VRD applications. This device can also be used in high-current System VRM (SVRM) applications where small size, high efficiency, and low total BOM cost is critical.

Electrical Specifications

Parameter	Test Conditions	Min	Typ	Max	Unit
Turns Ratio (1 - 2) : (4 - 3)	1Vrms @100 kHz		1:1		-
L_s (1-2)	0.1Vrms @ 500 kHz	525	675	825	nH
L_s (4-3)	0.1Vrms @ 500 kHz	525	675	825	nH
LL (1-2)	short 4+3, 1.0 Vrms @ 1 MHz		140		nH
DCR (each winding)	25°C	0.27	0.30	0.33	mΩ

1. This is RoHS Compliant product.
2. The nominal DCR is measured from point (a) to point (b), as shown on the mechanical drawing.
3. Operating temperature range: 0°C to 100°C.
4. Isat is the current at which the inductance drops by 25% max.
5. Meets UL 94V-0.

Specifications subject to change without notice.

ICL701-4 VRD/POL Inductor



Front View

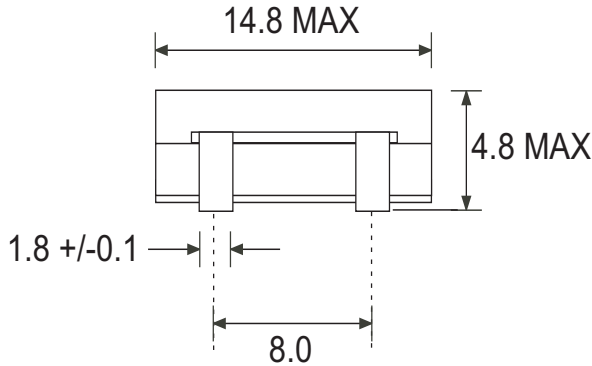

Schematic

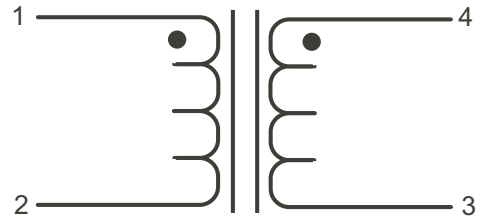

units: mm

Top View

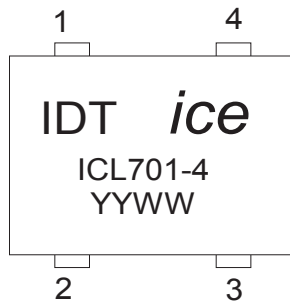

Side View

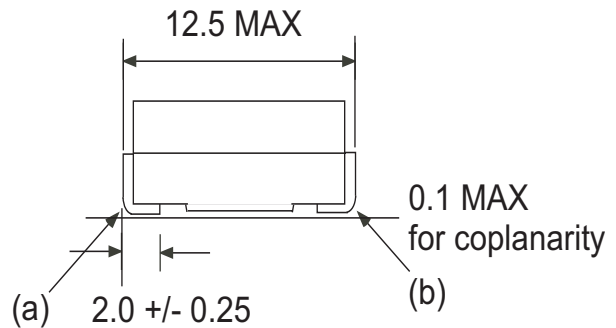

units: mm

Layout

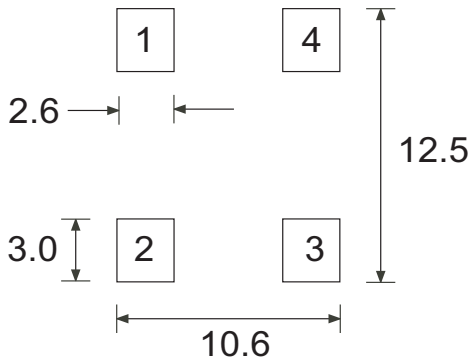

Inductance vs. Current

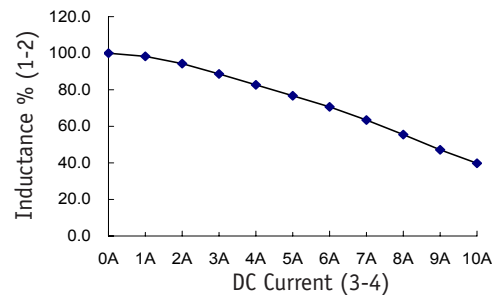

Magnetizing inductance (1-2) vs. DC current applied (3-4)

The technology utilized in conjunction with the coupled inductor (“the CL”) described in this data sheet includes intellectual property (the “IP”) owned by IDT, Inc. and is covered by one or more of the following U.S. patents: 6,545,450; 6,686,727; 6,696,823. In connection with the end customer’s purchase of the CL from “ICE Components, Inc.”, the end customer is hereby granted a non-exclusive, worldwide, royalty-free license (without rights to sublicense) to use and incorporate the IP in the end customer’s product that also incorporates the CL. In no way does this license extend to customer end products which do not incorporate the CL to implement the IP.

Specifications subject to change without notice.